

**SAFETY. EFFICIENCY.
INNOVATION.**

Solutions and components for food
processing and packaging



Optimise your system

**SAFER.
EFFICIENT. QUICK.**

The packaging sector is constantly evolving, where innovation is essential to remain competitive.

Thanks to our experience and expertise, we are able to offer cutting-edge products and solutions to guarantee reliability, efficiency and flexibility in every phase of food processing and packaging.



Application sectors:



CHEMICALS INDUSTRY



HOME CARE



FOOD & BEVERAGE



PHARMA & COSMETICS



TOBACCO

Food processing & primary packaging

In the first phase of food processing and primary packaging we put food safety and efficiency at the forefront.

We are aware that the direct and indirect contact with food, pharmaceuticals or cosmetics requires precise and reliable solutions that protect the product in terms of safety and hygiene.

APPLICATION AREAS

- Dosing/Forming
- Filling
- Packaging
- Selecting
- Sorting
- Protected atmosphere
- Food cutting
- Pick and Place

Secondary packaging

For secondary packaging, where the wrapping encloses or boxes one or more primary containers, we provide advanced solutions to guarantee maximum efficiency and reliability of the entire system (OEE). The high frequency of production cycles in this phase requires robust and highly resistant components that can quickly adapt to different application needs.

APPLICATION AREAS

- Packaging
- Vacuum/Closing
- Glueing
- Pick and Place
- Batch forming
- Thermoforming

Tertiary packaging

In tertiary packaging, the priority is focused on the safe and smooth handling of multiple containers. For this purpose, we provide robust and efficient components, ideal for managing lower speeds, with larger loads and substantial linear transfers.

APPLICATION AREAS

- Palletisers
- Wrapping machines
- Labelling machines
- Cartoning machines

Food processing and packaging line

CONTROL AND HANDLING TECHNOLOGIES FOR EVERY PRODUCTION PHASE

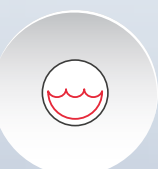
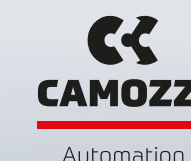

FOOD PROCESSING

COMPLIANT WITH REGULATION (EC) N° 1935/2004 AND FDA STANDARD



PRIMARY PACKAGING

COMPLIANT WITH NSF-H1 CERTIFICATION

CLEAN PROFILE AND RESISTANT TO CORROSION

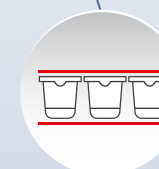

SECONDARY PACKAGING

APPLICATION FLEXIBILITY

IMPROVED MACHINE EFFICIENCY (OEE)

REDUCED FORMAT CHANGEOVER TIMES

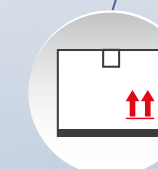

TERTIARY PACKAGING

ADAPTABLE TO DIFFERENT FORMATS

INCREASED LOGISTIC EFFICIENCY

HIGH LOAD HANDLING

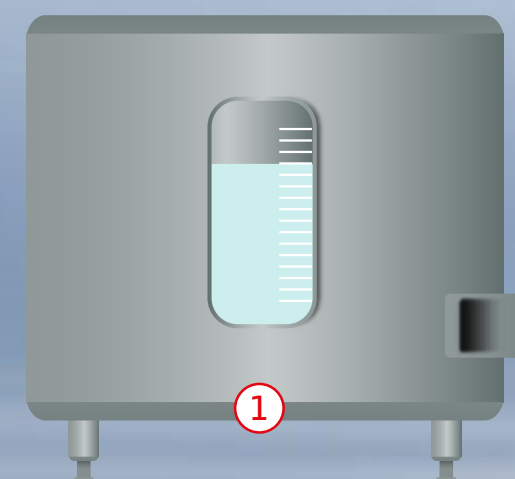

- Media separated valves
- Pilot valves and solenoid valves
- Stainless steel angle seat valves

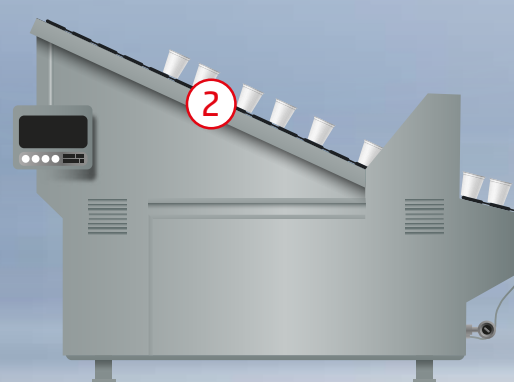

- Electromechanical cylinders
- Stainless steel cylinders
- Cylinders compliant with ISO standards
- Air treatment units with safety valves
- Air treatment units suitable for direct and indirect food contact
- Valve islands
- Proportional regulators

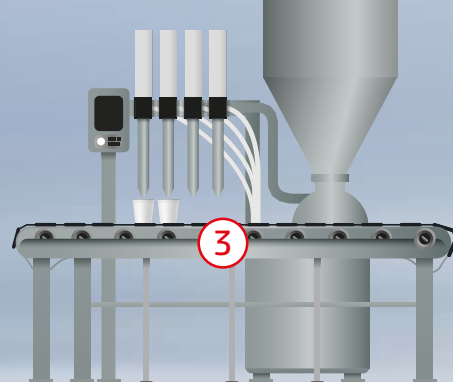
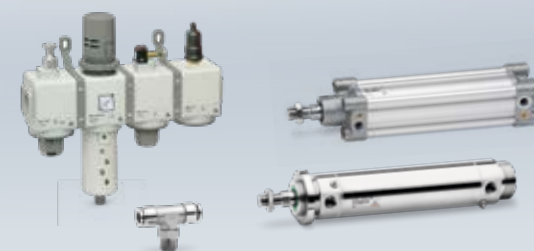

- Electromechanical axes
- Drives
- Electromechanical cylinders
- Cylinders compliant with ISO standards
- Ejectors
- Air treatment units with safety valves
- Valve islands
- Grippers
- Technopolymer fittings
- Proportional regulators
- Valves and solenoid valves
- Proportional valves
- Suction pads

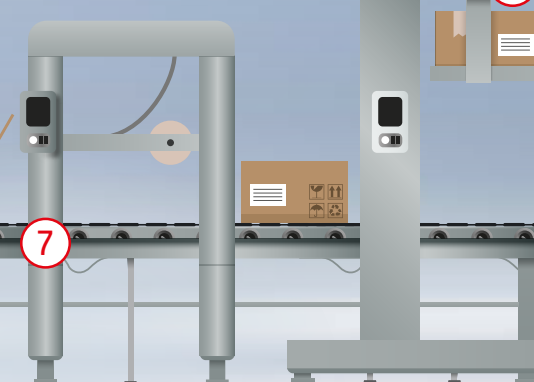
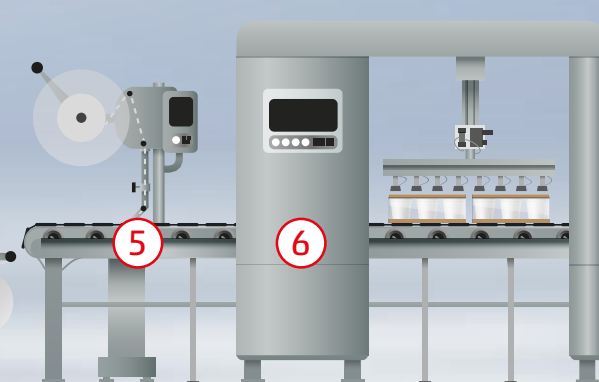

- Electromechanical axes
- Guided cylinders
- Rodless cylinders
- Ejectors
- Air treatment units with safety valves
- Suction pads
- Proportional regulators



- Tank (1)
- Conveyor (2)
- Filling (3)
- Sealing (4)
- Labelling (5)
- Cartoning (6)
- Closing (7)
- Palletising (8)
- Wrapping (9)

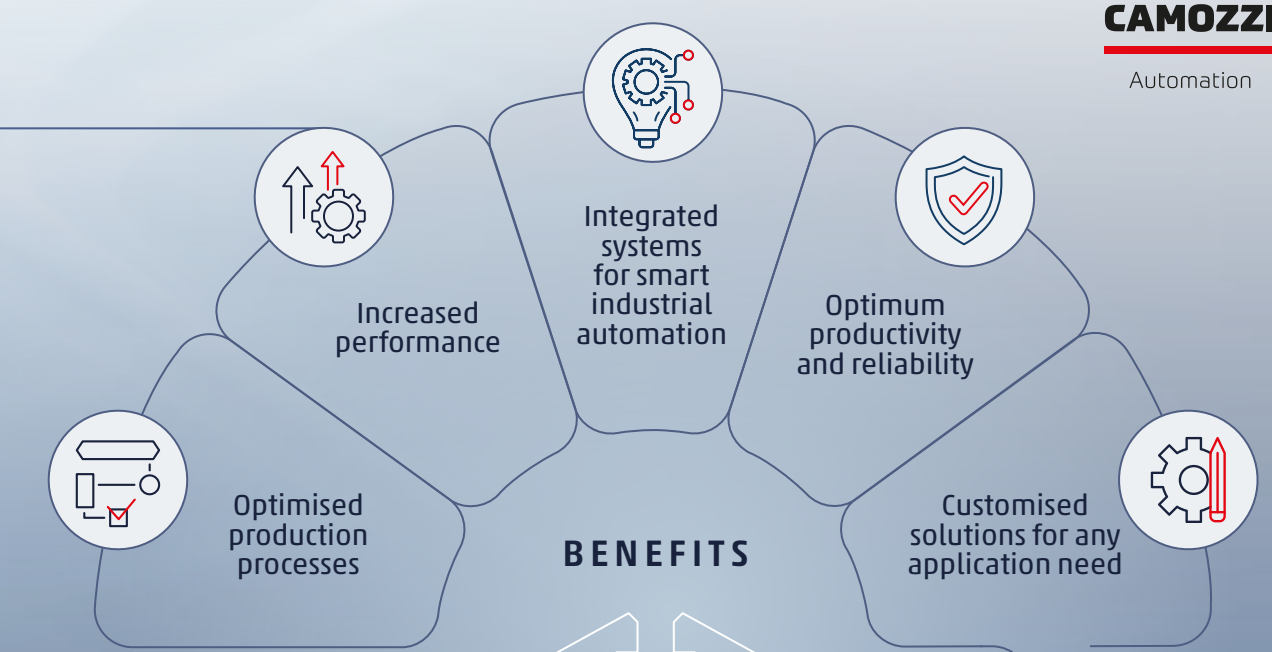
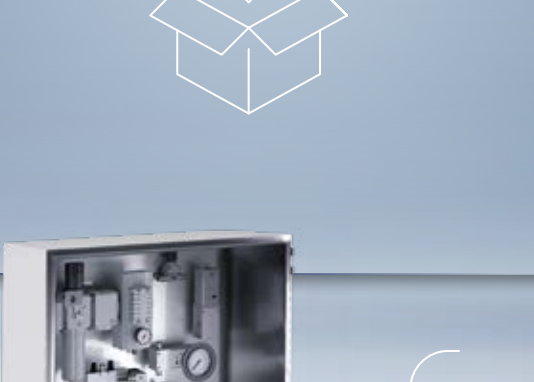

Customised solutions:

Complete turnkey solutions that provide the best way to **control** and **manage** your applications.



Automation

A Camozzi Group Company

camozzi.com

Contacts

Camozzi Automation S.p.A.

Società Unipersonale

REGISTERED OFFICE

Via R. Rubattino, 81

20134 Milano

Italy

OPERATIONAL HEADQUARTERS

Via Eritrea, 20/1

25126 Brescia

Italy

Tel. +39 030 37921

marketing@camozzi.com

Customer Service

Tel. +39 030 3792790

service@camozzi.com

Export Department

Tel. +39 030 3792253

sales@camozzi.com

